

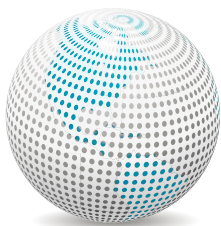

TOLAY STEEL BUILDING SYSTEMS

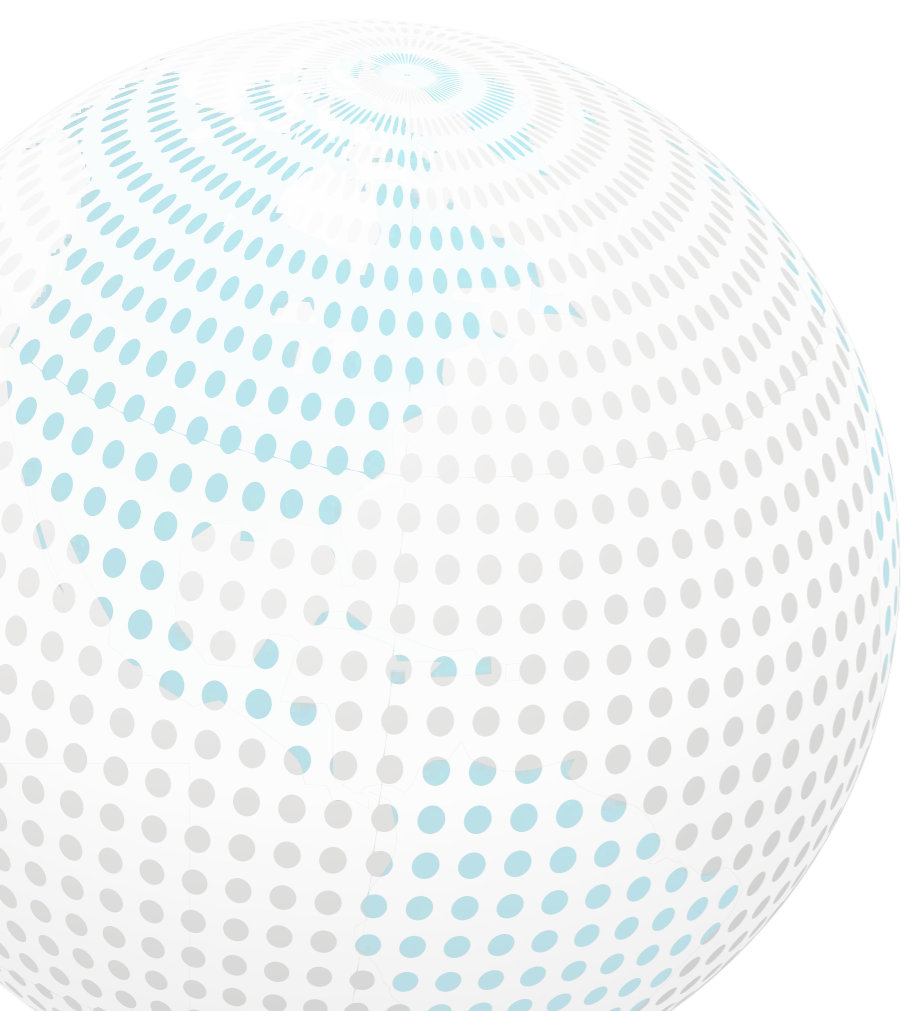

TOLAY STEEL
CONSTRUCTION AND PEB SYSTEM



TOLAY STEEL
CONSTRUCTION AND PEB SYSTEM



TOLAY STEEL BUILDING SYSTEMS



HOW DID PEB COME INTO BEING?

Steel construction demands increased dramatically as such factors as time, economy, increasing storage and sheltering needs, duration, mountability and building's safety against earthquakes gained importance under the current conditions. However; the facts that design rules of the conventional method were not economical, the design didn't offer any features to buildings and ready-to-use hot mill elements were constantly dependent on prevented steel buildings from becoming widespread in international markets for many years.

The development enjoyed by information technologies and engineering in recent years offered modern solutions for building design and consequently the revolutionary PEB building design system came into being.

This innovative design system made important contributions to meeting steel construction needs and increasing market share throughout the world.

PEB system has increased its market share rapidly since its introduction to the market. It increased its market share up to 60% especially in the USA according to the report published by the Association of International Metal Manufacturers. In 1990s, PEB entered India which is one of the leading countries of the world in steel production by making foreign investments in this country. PEB's market potential reached 1.2 million tons and its present production capacity was determined to be 0.35 million tons/year. At the same time, PEB increases its market share in this country every year by 25 - 30 per cent.

WHAT IS PEB?

In conventional systems a single section big enough to compensate for the maximum stress is used while different stresses occur at each point of the frame constituting the building. This situation adds unnecessary weight on the building; increases the earthquake load falling onto it as well as increasing its cost and reduces building's elastic mobility.

PEB system arose from the need for removing such

disadvantages of the abovementioned conventional system. PEB is a modern building design system which sets forth the production of artificial profile sections in various sizes according to the capacity needed by construction elements by taking as a basis the fact that stress concentrations vary in the system constituting the building. This system lightens the building, provides it with an elastic and economical structure and removes the dependence on ready-to-use profiles.

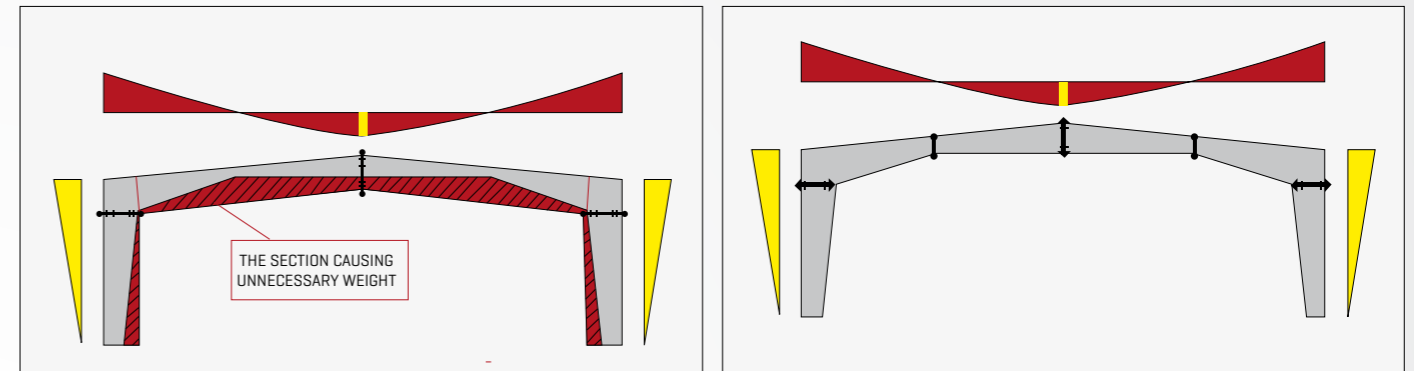

Conventional Steel Frame

Peb Steel Frame

*No more unnecessary weights on your steel constructions...
Your steel constructions will be **%30** cheaper...*



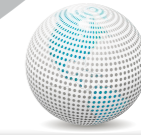

ADVANTAGES OF PEB SYSTEM



Cost: Peb system is rather economical in comparison to conventional systems. As agreements are made according to turn-key principle, it doesn't cause employers any unexpected costs. Cost reduction is not limited to steel constructions; infrastructure [foundation concrete, excavation etc.] costs are also reduced dramatically. No welding works are applied in the construction site. All joints are bolted. In case of any need, construction materials can be removed and used for other projects. This is a cost-reducing factor as especially the buildings which are used for a short period can be made use of in many other projects. Besides; as projects and relevant details are prepared by the producers, deducting design costs will also reduce the total cost amount.



Instant Installation: Installation period is very short as all products are bolted. This time reduction is a general cost-reducing factor for employers.



Recycling: Recycling duration of this investment is much shorter in comparison to other systems.



Strength and Safety: Sustainability of the buildings is ensured for long years without much maintenance need as all secondary steel elements are galvanized, primary elements are sandblasted and painted in the factory and all steel elements are prevented from being exposed to damp, condensation and corrosion thanks to the use of proper isolation systems.

In addition, the unnecessary steel elements used in conventional systems make buildings heavy. As is known, earthquakes' impacts on the buildings are directly proportionate to their masses. Earthquakes' impacts reduce at the same rate as buildings get lighter. At the same time, buildings' being unnecessarily heavy causes them to exceed ground bearing capacity.

As unnecessary heavy profiles are used in conventional systems, more stress concentrations occur on joints. No matter how heavy is the profile you are using, a building's safety is indexed to the success of the foreman welding under difficult conditions at the joints, on a ladder. In short, it is indexed to human factor. If any defect occurs in the welding applied to joints, the system may come to the brink of collapsing because of the junctures occurring in these areas.

In PEB system, all welding works are performed in the factory with robots and under the control of welding foremen. As buildings are light, the stress concentrations taking place on joints are reduced. Safety is not indexed to human factor any more since all joints are bolted.



Working Safety: Duration of the installation works performed on the construction site which is under employers' responsibility will be reduced, become practical and risk of work accidents will be minimized as 90% of the manufacturing period is completed in factories, all joints are bolted [not welded] and not even painting works are not performed on the construction site.



Low Maintenance and Operation Costs: Maintenance and operation costs of the buildings constructed with this system are rather low in comparison to other conventional buildings. Buildings maintain their new appearance for many years. They can even be removed and used in other projects.



Versatility and Architectural Design Flexibility: In PEB system, single storeys and mezzanines can be designed in the required roof type, session, space and height according to employers' needs.



Energy Saving: As the isolated materials and secondary steel elements used in buildings are designed to block air bridge, in summer hot air and in winter cold air are prevented from affecting buildings. At the same time, they don't allow moisture and damp formation in indoor area; prevent unnecessary energy consumption.



Longevity: You can be sure that you will have a building which will exist for long years thanks to high quality metals and joint elements.



Environment Friendly: 90% of the materials used in PEB system can be recycled.



USAGE AREAS OF PEB SYSTEM

Warehouses



Factories



Ateliers



Vehicle Park Shelters



Showrooms



Airport Hangars



Recreation Areas



Stadium Roofs



Outdoor Canopies



Offices



Petrol Stations



Subway Stations



Bridges



Schools



Stud-Barn



PEB systems are compatible with all architectural designs.

PEB CRITERIA

Design: The data obtained about PEB system throughout the world from the combination of science and engineering was reduced to systematic and special software was prepared. Thus, draft projects and cost estimations can be prepared free of charge in a short duration.

Cost estimations are prepared within three working days. In case of agreement, approval projects are prepared within 7-10 working days while whole projects are prepared within 15 working days. As offers are based on turnkey principle, the time required by employers for making recycling and cost calculations is quite reduced. Besides, employers don't need to allocate neither an employee nor any costs for this.

Basic Materials: High-strength S355 [St-52] steel materials are used in PEB systems.

Foundation: No turning effect is experienced in the foundations as foundation joints are hinged. So, solutions can be developed with much more economical foundation sizes.

Accessory: Such closing accessories as doors, windows etc. can be manufactured in various sizes according to relevant standards.

Delivery Period: Nearly 8-12 weeks

Installation: Installation works are performed in a short, simple, step-by-step and fast way according to the work schedule prepared based on the experience obtained from manufactured buildings.

Architectural: PEB system can be applied to all building types by using architectural expertization.

Cost: Its m² cost is 30 - 40% more economical in comparison to conventional steel and other buildings.

Coordination: When requested; linings, accessories and fitting materials as well as facing and roofing services are also offered. Thus, employers can make coordination more easily by working with a single contractor over a single cost.

Changes: Changes can be added to the system without increasing the cost a lot.

Responsibility: The whole responsibility is assumed by one contractor. So, the authorization chaos occurring when there is more than one contractor is eliminated.

Performance: All manufacturing components were designed to deliver accurate and efficient performance. As a result, the buildings constructed with their combination also deliver high performance.

PEB DESIGN

PEB Design Systems are based on rigidity matrix method and allowable stress design principles. Load combinations and specifications are left to user's wishes. All national and international design codes and standards can be used.

DESIGN CYCLE

Design cycle consists of the following steps

- 1- The loads in the preferred specification are entered to the system.
- 2- Axial force, shearing force and moment values are detected at all analyzed points for each load combination.
- 3- Shearing, axial and bending stress rates are compared with present and allowable stress values.
- 4- Optimum additional locations are designed and preferred sizes are checked to comply with manufacturing.
- 5- Joist depths appropriate to the cycle are reached by using the optimization mode of bodies and relevant data is renewed.

FRAME GEOMETRY

PEB system has the chance to solve different types of geometrical load-bearing systems as follows.

- Different type rigid frame, single or multiple span systems,
- Systems with different spans, different heights and different slopes
- Jointed, built-in, partial supported systems,
- Systems in different symmetric and asymmetric modules,
- Buildings constructed according to geometrical design determined by users,

PEB system can be used at up to 30-40m heights both in single-storey and multi-storey buildings. They can be applied at up to 80m in spans.

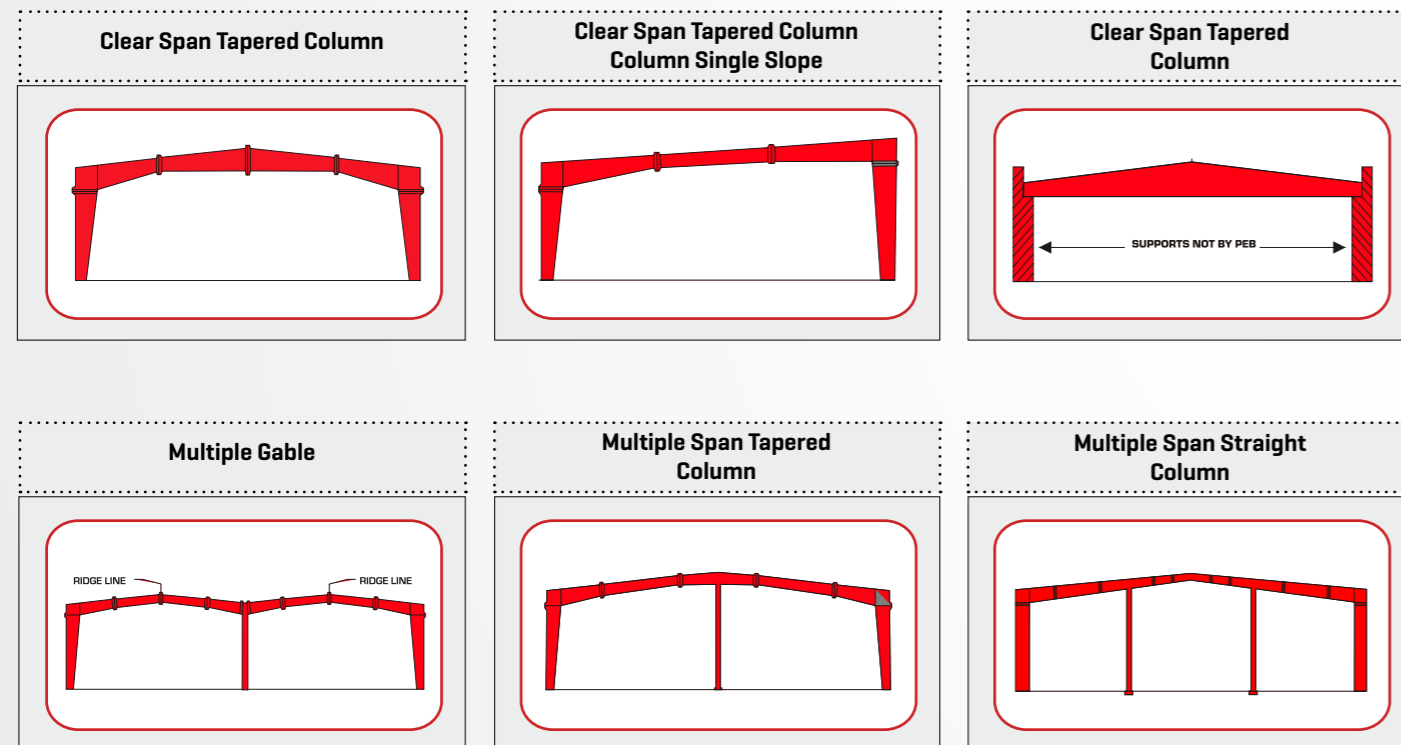

FRAME LOADS

In frame design, loads are handled as follows.

- All dead loads are adjusted to the system according to the self weight of frame elements.
- Desired moving loads are taken according to the codes used.
- Complementary loads; wind speed is also entered according to wind pressure units, preferred specification values are used according to users' wishes.
- Coefficient demand can be changed appropriately.
- Crane loads or non-crane loads can be defined by users. The program has also such features as special loading and combining other loads.
- Seismic loads and different zone categories can be defined according to different international codes. Required heat loads, heat differences and thermal expansion coefficients are applied according to users' wishes.

DESIGN CODES AND STANDARDS

Design Codes

- TDY Turkish Earthquake Regulation – TR Ministry of Public Works and Settlement
- MSC Manual Steel Cons. – American Institute of Steel Construction, Inc. [AISC]
- CFSD Cold Formed Steel Design Manual – American Iron and Steel Institute [AISI]
- AWCSM American Welding Code Steel Manual – American Welding Society [AWS]

Standards

- UBC Uniform Building Code – International Building Code, Inc. [IBC]

- MBSM Metal Building Systems Manual – Metal Building Manufacturers Association, Inc. [MBMA]
- TS498 Sizes of Construction Elements, Calculation Values of the Loads to be taken – Turkish Standards Institute [TSE]
- TS648 Calculation and Building Rules for Steel Constructions – Turkish Standards Institute [TSE]

DESIGN PROCESSES

Frame data is combined according to the number of frames, connection points, freedom degrees, limitations and elastic characteristics. This way, data is stored and elements sections are calculated.

All rigidity matrixes based on frame data which takes into account all possible deflections are obtained. Load vector is obtained by summing up multiplied load vector, all reversible rigidity matrixes and unknown displacements.

PEB COMPONENTS

There are 3 types of construction elements in PEB systems.

- Primary Steel [Built Up Sections]
- Secondary Steel [Secondary Members]
- Accessories [Accessories, Flashing and Trims]

PRIMARY STEEL ELEMENTS (BUILT UP SECTIONS)

They consist of three construction elements; variable frame, stability connections and flange supports. Stability and flange supports are the elements helping frame design.



a-) Variable Frame

In PEB systems, sections vary according to the statuses of stress concentrations while steel frames, columns and joists follow only one section in conventional systems. Variable frames consist of joists and columns. Rigid frame is the main bearer of building system.



b-) Stability Connections

Profiles, rods and cables are generally used for this purpose according to span, height, axis number, wind and earthquake loads. They enable the transfer of horizontal forces to ground level as well as enabling load transfer. They maintain general stability of buildings.



c-) Flange Supports

Flange supports are beneficial elements which support flanges of the profiles they are attached to and at the same time reduce bearing distance by helping moment transfer of the purlins. Corner profiles are usually preferred. They are used as double-sided on ridge and barge parts of frames while being used as one-sided on other parts.

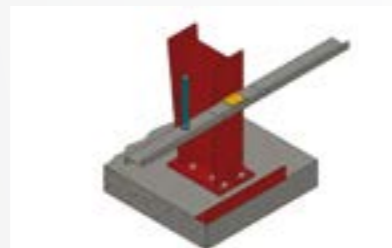

SECONDARY STEEL ELEMENTS (SECONDARY MEMBERS)

Secondary steels are the supporting elements which support roof and wall lining connections as well helping to transfer loads to the primary steel. Secondary steels are rather used in purlins, face bands and barges. The mill profiles used in these areas in conventional systems are heavy but their inertia values are low.

Their bearing capacities are not so high although heavy and costly mill profiles are used. Z or C profiles manufactured with cold form in required sizes and strength levels by using galvanized sheets which have high yield strength and comply with ST 52 standard are used in PEB system. These profiles are both economical and have a higher bearing capacity.

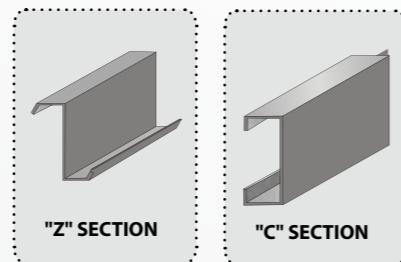

Some Examples for Secondary Steel Members



a-) Purlins

They are usually design as Z section in cold form. Their depths vary between 200-250 mm while wall thicknesses vary between 1.5 and 3mm. Purlins are fixed to the upper flanges of variable section frames with clips.



b-) Face Bands

They are usually design as Z, C or Omega sections in cold form. Their depths vary between 200-250mm while wall thicknesses vary between 1.5 and 3mm. Bands are fixed to the exterior flanges of variable section frames' exterior columns with clips.

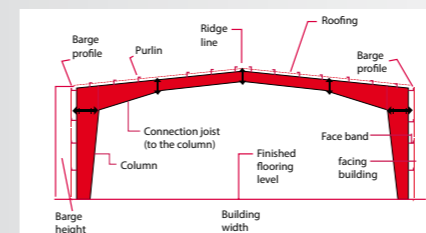

c-) Barge Profile

They are usually designed as Z or C sections in cold form. Their depths vary between 200-250mm while wall thicknesses vary between 1.5 and 3mm. Bands are fixed to the exterior flanges of variable section frames' exterior columns with clips.



d-) Wind Columns

They help to reduce span and deflection values by supporting face bands against the wind loads to come front and back faces.

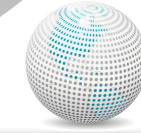

ACCESSORIES (ACCESSORIES, FLASHINGS AND TRIMS)

These are the profiles manufactured with cold bending which are used to help facing and roofing installations, heat and water isolation as well as the prevention of heat bridge constitutions. They are used in internal-external closings, hood molds, windows, doors, all endings and many interior places.

Accessory elements are usually examined in four groups:

- Gutter and decline accessories,
- Corner flashings
- Ridge accessories,
- Door-window accessories

SOME EXAMPLES

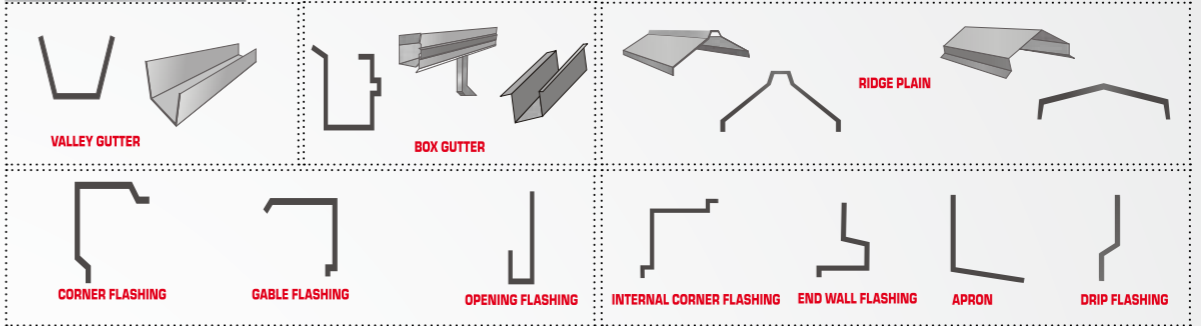

MEZZANINE FLOORS

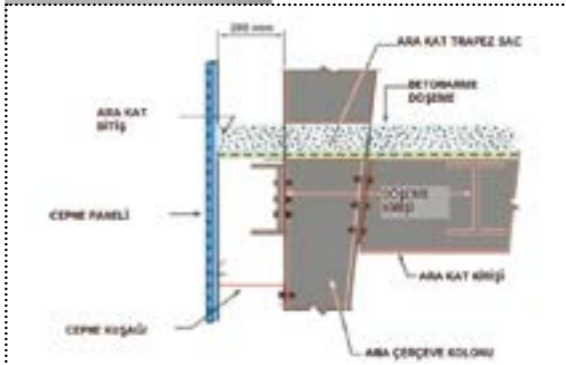

DETAILS ON THE CONNECTION BETWEEN MEZZANINE JOIST AND MAIN COLUMN

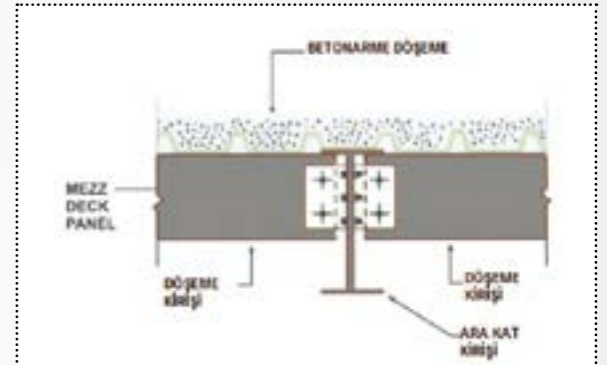

DETAILS ON THE CONNECTION BETWEEN MEZZANINE FLOORING JOIST AND MEZZANINE JOIST

In PEB systems, mezzanines are also built according to above details. Mezzanines may be single floors within the building or they can be in parts. Mezzanine elements are trapeze sheet, flooring, floor joist profiles and concrete. Multi-staged equipment platforms, catwalks and staircases can be adapted to the project.

CRANE BUILDINGS



PEB system can be designed easily in all crane buildings.

HIGH-RISE BUILDINGS



Offering architectural freedom with its lightness, formability and wide span crossing features, PEB can be applied to high-rise industrial buildings and all house-type buildings.

BARGE GUTTER INSTALLATION

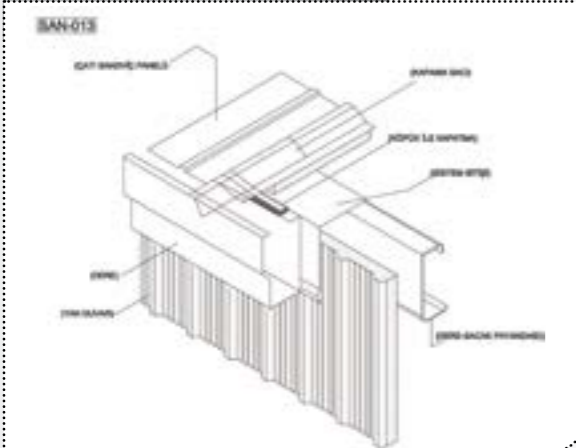

FRAME CROSS

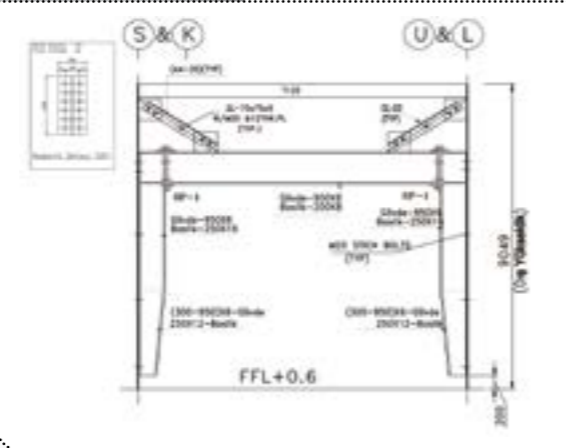

FOUNDATION DETAILS (PARTIAL WALL)

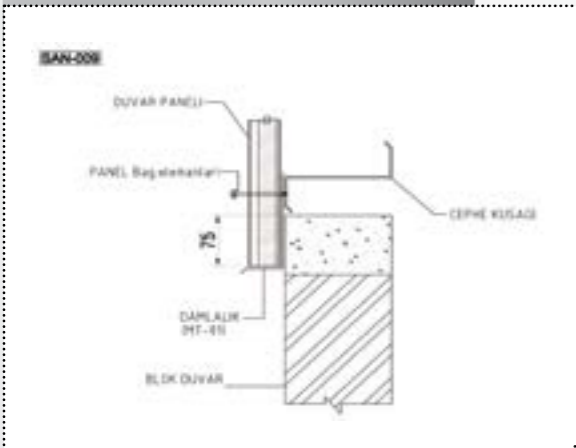

WALL PANEL DETAIL (ISO APPEARANCE)

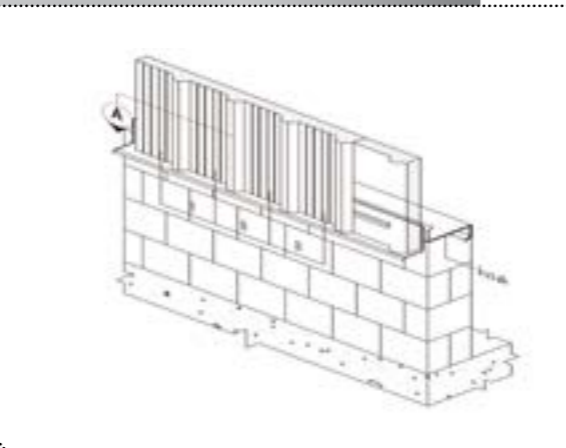



EXAMPLES FOR MILL AND COLD PROFILE BEARING CAPACITIES

Safe design is only possible by designing in accordance with engineering rules not by making buildings heavier.

Z SECTION

Z20 Section Features [Safety Stress for ST52 Steel: 2,16 t/cm²
W_x=47,55 cm³

$$G=5,90 \text{ kg/m}$$

$$M_{\max} = \sigma_{\text{em}} \times W_x = [2,16 \text{ t/cm}^2] \times [47,55 \text{ cm}^3] = 102,71 \text{ tcm}$$

UPE140

Safety Stress for ST37 Steel: 1,44 t/cm²

$$W_x = 85,64 \text{ cm}^3$$

$$G=14,5 \text{ kg/m}$$

$$M_{\max} = \sigma_{\text{em}} \times W_x = [1,44 \text{ t/cm}^2] \times [85,64 \text{ cm}^3] = 123,3 \text{ tcm}$$

Weight differences between a mill profile and a cold form profile used to carry a moment of 100tcm.

$$\text{UPE 140} = 14.5 \text{ kg} / \text{Z20} = 5.90 \text{ kg} \quad \text{difference} = 2.46 \text{ folds}$$

Example 2

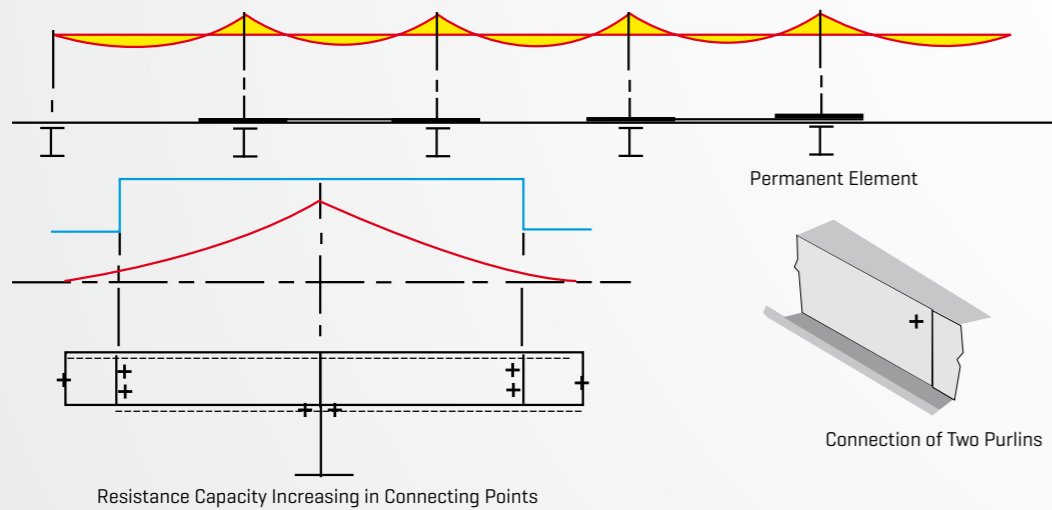

As is seen in the figure; Z profiles are tucked in each other on locations where additional parts fall onto frames. They are connected with bolts and fixed on the frame with their clips. Braces are made more rigid by using flange supports; they are enabled to receive moment. Continuity is maintained, moment values of the middle area which is the most unfavorable section are reduced to more reasonable limits.

CONSTRUCTION COMPONENTS IN PEB SYSTEM

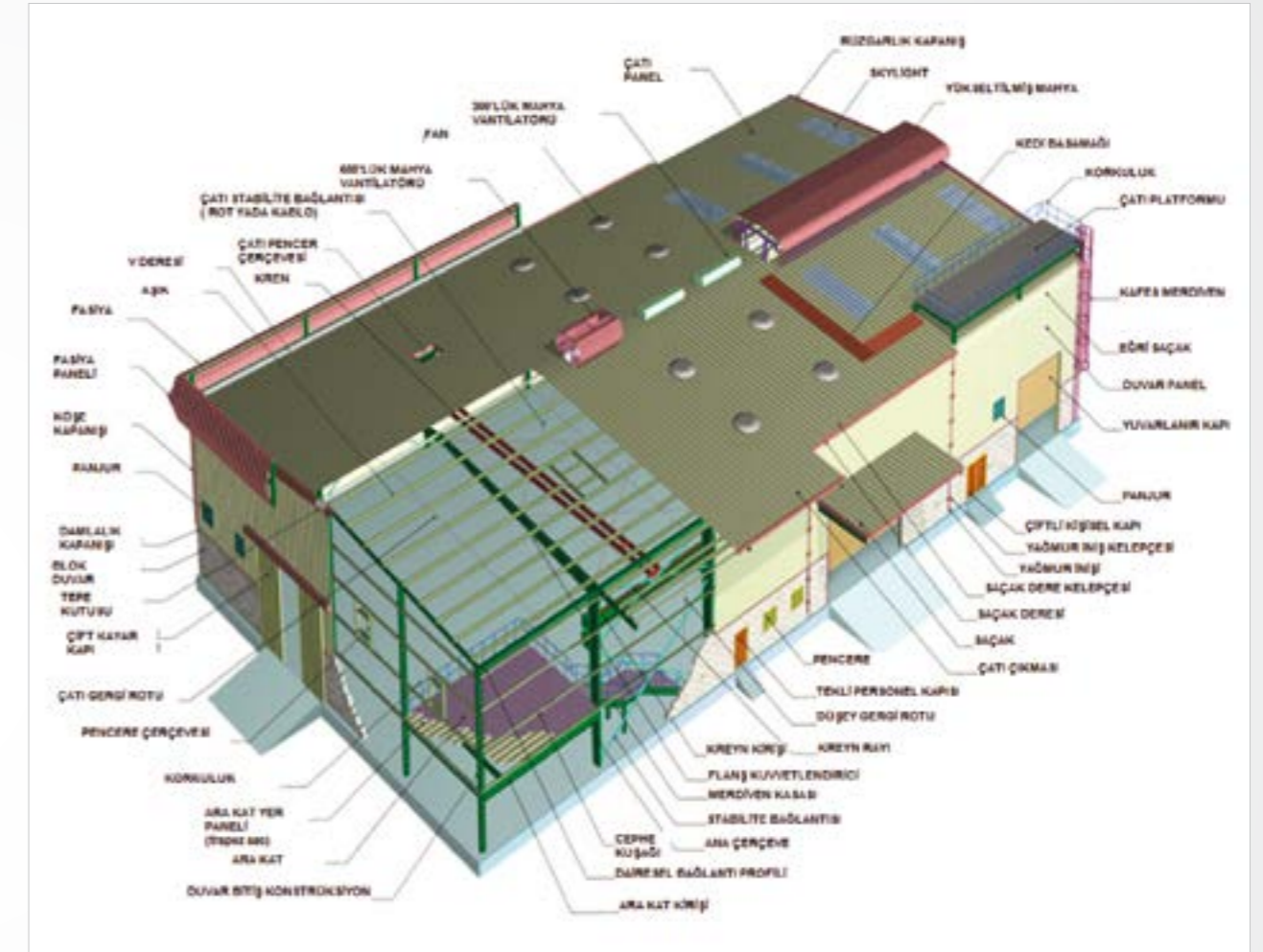

In our country, steel which is one of our biggest import items is consumed so much by still applying classical engineering rules without bothering to perform R&D activities while it is consumed economically in all developed countries of the world by applying engineering methods. This situation causes high costs for the investors.

- Stopping unnecessary steel use thanks to more economical solutions,
- Getting the worth of investments in very short periods,
- Reducing business costs,
- Having a safer building against earthquakes,

These are all possible now.

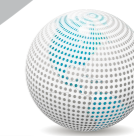

TOLAY STEEL / LIGHT STEEL HOUSE WHY TOLAY STEEL / LIGHT STEEL?

Economic

The term "being economic" in light steel structure systems should be assessed from several perspectives. These could be divided into main categories such as application economy, usage economy and contractor economy.

In application economy, as they are constructed in a shorter period of time when compared to reinforced systems, and workforce losses, effects of climate conditions and general costs are less and users can move to their houses in a shorter period of time, they will be affected by costs such as rent etc. less. Therefore, they are preferably chosen as they are more economic during application when compared to reinforced concrete system.

In terms of usage costs, as they are more comfortable and maintenance-free buildings when compared to reinforced concrete systems, usage costs are at minimum levels. In light steel systems, heat, noise and fire resistance are higher than reinforced concrete systems and it is easier to increase this quality. As heating and cooling operations will be easier than reinforced concrete systems due to these kinds of reasons, fuel costs will be less. Another factor is that damage ratios will be lower in light steel structures which are more resistant than reinforced concrete systems after natural disasters, and these damages can be mended with minor repairs.

By analyzing the economy from an investor's point of view, investments made will return in a short period of time due to the cost-effectiveness obtained in implementation, and also return of investment costs will be shorter in line with the duration of construction. In this way, a 4 time faster cycle will be created when compared to reinforced concrete buildings.

Environment-friendly

As the entire light steel construction system is made with pre-produced materials in factory, recycled materials can be also used. A load bearing system can be created by producing steel by the recycling of 6-10 car scraps for a house. Thanks to this recycling, reduced raw material reserves are protected. If it is necessary to demolish this house, raw material obtained can be used in recycling.

It is observed that recycling ratios of the materials used for a reinforced concrete structure of the same size is very low. As the ratio of materials sent for recycling after demolition of reinforced concrete systems will be low, it will cause the number of waste areas to increase. When house is constructed as wooden, approximately 50-80 trees will be cut and used to make carcass.

Flexible

Flexibility is the privilege for the owners of light steel houses. For the integration of rapidly-changing living standards and styles with our spaces, repairs within house can be made easily, quickly and cost-effectively in light steel house system. All operations such as making modifications that you desire to make in your light steel house after years, removal of non-bearing walls, re-partition of rooms and opening gaps such as doors and windows can be made more quickly and cost-effective than other structure systems.

Construction Speed is High

As all components of light steel structural system are produced in factory and then shipped to the construction site, they can be easily installed without need for any production. Application can be approximately 4 time faster in a two-floor building when compared to reinforced concrete system.

Strong

Light steel structural system is a system whose ratio of specific gravity to the load borne by it is very low than reinforced concrete structural style. Light steel ensures that structure is affected less by the factors encountered such as earthquake. Steel is the strongest structural material when compared to classical materials used in other structural systems because it is lightweight, its elongation resistance is high and it demonstrates the best position in overloading and the best behavior forms under load.

High-Quality

As light steel structures are completely made with pre-produced materials in factory from load bearing system to topcoat material, they are produced in accordance with all relevant building standards. As they comply with

the standards, all materials used in light steel structural systems are produced and used without making concessions on quality.

Light steel structural systems will be always one step ahead of all other structural systems without making any concessions on quality, as a result of combination of building materials that comply with standards and construction technique that does not require interpretation by workers.

Easy to Inspect

As light steel structural systems are transparent systems, it is easy to inspect all installation and production activities as there is no hidden, invisible or inaccessible area while making other productions. This ease of inspection ensures that error ratio is kept at minimum levels.

Comfortable

In light steel structural systems, the interior environment can be kept at the required temperature irrespective of external weather conditions, thanks to the high heat insulation. Internal and external noises can be prevented thanks to the high noise insulation. Comfort is achieved with all of these types of factors.

TOLAY STEEL LIGHT STEEL HOUSE SYSTEMS

1-) TOLAY STEEL / LIGHT STEEL HOUSE SYSTEMS, SYSTEM DESCRIPTION

In accordance with the static calculations, architectural design and project data by the region and project:

[DIN EN 10326] standard;
[S320GD+Z,+AZ] [Erdemir quality no: 1332]
Yielding point: 3200 kg/cm² [320 N/mm²]
Tensile strength : 3900 kg/cm² [390 N/mm²]

[S350GD+Z,+AZ] [Erdemir quality no:1335]
Yielding point: 3500 kg/cm² [350 N/mm²]
Tensile strength: 4200kg/cm² [420 N/mm²]

Steel material that has the above-mentioned properties is used.

We call our house systems, which are designed with all advanced rough and fine products, and whose Light Galvanized Sheet, special-size profiles and main bearing systems were produced, as "TOLAY STEEL / LIGHT STEEL HOUSE SYSTEMS".

2-) TOLAY STEEL / LIGHT STEEL HOUSE SYSTEMS, BEARING SYSTEM PRODUCTION TECHNOLOGY

The production is carried out by fully-automatic roll-forming machines. The profiles that constitute the construction and all necessary forms are created by Continue profile line, and all installation and connection gaps are drilled under full computer control. Welding is never used during production and installation process. Joining is carried out with special norm bolts and/or screws.

Seismic and static calculations that are required according to the location of the construction are done by Sap2000, CFS, STA4CAD, BRICSCAD, HAYESCAD program according to the load values described in project and standards.



Structural System / Production - 1

3-J) TOLAY STEEL / LIGHT STEEL HOUSE SYSTEM, COMPLIANCE STANDARDS

3-A) STEEL AND CONSTRUCTION

TS 11372: Steel Structures – Light – Consisting of Cold Formed Profiles – Calculation Rules

TS 648: Calculation and Construction Rules of Steel Structures

TS 6793: Use and settlement loads in Houses and Public Buildings

TS 498: Calculation Values of Loads to be taken for the Sizing of Construction Elements

TS 7046: Rules for Design of Structures

TS ENV 1993-1-2: [Eurocode 3] Design of Steel Structures Part 1-2: General rules- Structural design against fire

TS 4561: Calculation Rules of Steel Structures According to Plastic Theory

TS ENV 1090-1: Steel Structure applications–Part 1:General rules and rules for buildings

TS ENV 1090-3: Steel Structure applications–Part 3: Additional rules for steels with high yield strength.

TS ENV1998-3: Eurocode 8: Preparation of Projects for earthquake-resistant structures- Part 1: General rules, seismic effects and rules for buildings.

TS EN 10326: Continuously hot-dip coated strips and sheets made of structural steel-technical delivery conditions

TS EN 10327: Continuously hot-dip coated strips and sheets made of low carbon steels for cold forming purpose-technical delivery conditions

TS EN 10162: Steel profiles- Cold rolled- Technical delivery conditions- Size and cross-section tolerances



Structural system / Assembly - 1



3-B) INSULATION VALUES (HEAT-ENERGY, ACOUSTIC, NOISE, SU)

TS 825: Rules for Heat Insulation in Buildings

TS 901-1 EN 13162: Heat insulation products – Used in buildings- Factory-made mineral wool products – properties

TS EN 12086: Heat insulation materials – Determination of Water Steam permeability properties for buildings
DIN 4109: Acoustic sound level required in houses

TS 2381-2 EN ISO 717-1: Acoustics- Assessment of noise insulation in structures and building elements- Part 1: Insulation of Airborne Sound

TS 2381-2 EN ISO 717-2: Acoustics- Assessment of sound insulation in structures and building elements – Part 2- Insulation of impact sound.

TS EN 29052-1: Acoustics- Determination of dynamic

stiffness – Part 1: Materials Used Under Flexible Flooring in Houses.

TS 7316 EN 13163: Heat insulation products- for buildings- made as fabrication –expanded polystyrene foam – properties

TS EN 13500: Heat insulation materials- used in structures- external, mineral wool based composite heat insulation systems (ETICS)-properties.

3-C) FIRE RESISTANCE STANDARDS

DIN 4102: Fire behaviors of building materials and building elements

TS 1263: Fire Resistance Classes of Building Elements and Fire Resistance Test Methods

DIN 1365-1: Fire resistance tests –For load bearing elements – Part 1: Walls

DIN 1365-2: Fire resistance tests –For load bearing elements – Part 2: Floorings and roofs

TS EN 13501-1: Building products and building elements, fire classification part 1: Classification by using the data obtained from fire behaviors tests

3-D) CONNECTION AND ASSEMBLY COMPONENTS STANDARDS

TS EN 20898-7: Mechanical properties of fasteners

TS 3611EN 20898-2: Mechanical properties of fasteners – Part 2: Nuts with Test load values determined- Normal step

3-E) EXTERNAL AND PARTITION WALL STANDARDS

TS EN 520: Gypsum boards – Descriptions, requirements and test methods

TS 1475: Rules for Placing Gypsum Partition Wall Board and Components

TS EN 12369-1: Wooden-based boards – Characteristic values for structural-purpose design –Part 1: OSB, particle boards and fiberboards

TS EN 300: Oriented Strand Boards (OSB) – Descriptions, Classification and Properties

TS EN 12369-1: Wooden-based boards – Characteristic values for structural-purpose design – Part 1: OSB, particle boards and fiberboards.

3-F) ELECTRICAL INSTALLATION REGULATION

Electricity Internal Installation Regulation no 25494 dated 16 June 2004

Electrical Facilities Grounding Regulation no 24500 dated 21 August 2001.

3-G) GENERAL REGULATIONS

R.G.26.07.2002 / 24822: Regulation on Protection of Buildings against Fire

ABYHYH 2007: Regulation on Structures to be Constructed in Disaster Areas



Structural System / External and Partition - 1

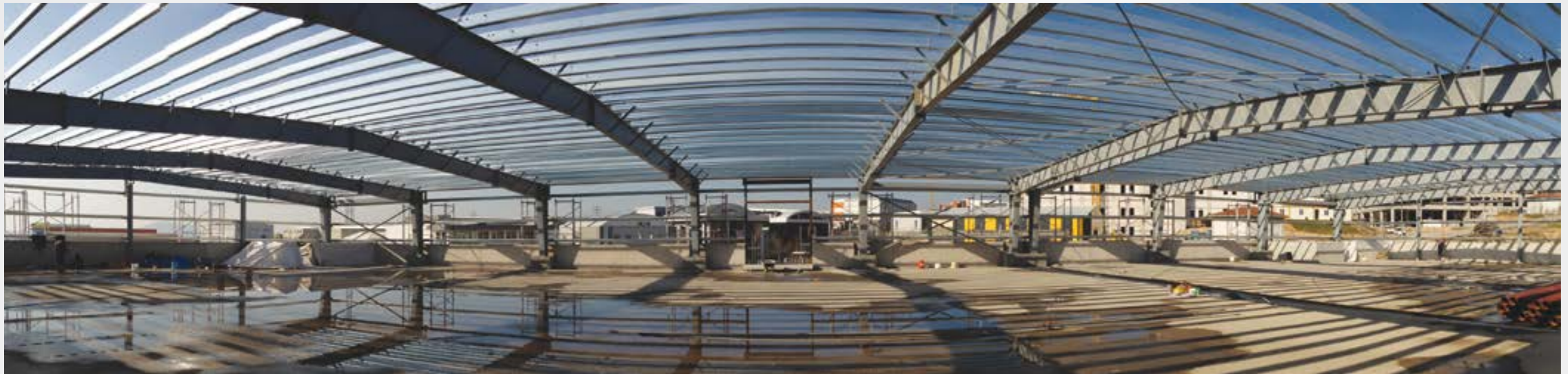









TOLAY STEEL
CONSTRUCTION AND PEB SYSTEM

Oruç Reis Mah. Vadi Cad. İstanbul Ticaret Sarayı
No: 108 İç Kapı No: 543 Esenler/İstanbul
Tel: +90 212 351 12 40
www.tolay.com.tr · info@tolay.com.tr